

Assembly Instructions for Adirondack Chair

Tools needed for assembly: Philips head screwdriver, Wrench and Allen key

- Step 1. Lay out the parts and identify each one by comparing them with the drawing below.
- Step 2. Attach left and right back legs (with countersink inwards) to seat support with four bolts and nuts. Do not fasten them.
- Step 3. Fit back to seat with four screws on upper back support and then lower back support.
- Step 4. Fit back support with four screws into inside of back legs.
- Step 5. Attach two front legs to bottom of left and right armrests with eight screws and dowel. Do not over tighten so as to avoid screw penetrating through armrest.
- Step 6. Attach armrests with leg to the assembled seat with back with four bolts and nuts through seat. Do not fasten them. And then fit rear of armrest to back leg with four screws.

Go back over the chair and tighten the screws and bolts.

It may be necessary to tighten screws and bolts over the years.

Enjoy your Adirondack chair.

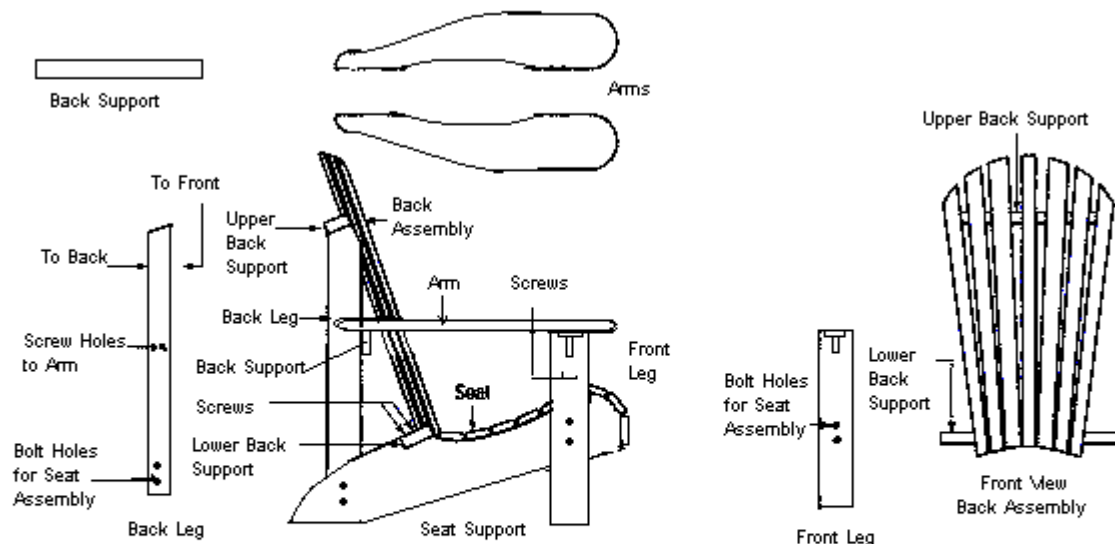

Parts List For Chair

1 - Seat Assembly	2 - Front Legs	8 - Bolts
1 - Back Assembly	2 - Back Legs	20 - Screws
2 - Arms	1 - Back Support	