

Recycled

POLY-WOODTM Inc.

ASSEMBLY INSTRUCTIONS

Models PWGL, PWGL-CB, GACGL, CACGL

STEP 1

ATTACH THE SEAT TO THE SIDEFAME USING QTY. 4 ¼-20 X 2½" BOLTS, WASHERS AND NUTS IN PREDRILLED HOLES (B)

* DO NOT TIGHTEN NUTS.

STEP 2

ATTACH THE BACK TO THE SIDEFAME USING (4) #10X3 PAINTED SCREWS IN PRE-DRILLED HOLES (A)

STEP 3

CONNECT THE GLIDER FRAMES TOGETHER USING (8) #10X3" PAINTED SCREW IN PRE-DRILLED HOLES (A2)

NOTE. CROSS-BRACE HAS ONLY THE TOP HOLE PRE-DRILLED FOR PROPER SCREW SPACING

STEP 4

ATTACH THE GLIDER HANGER TO THE CHAIR USING (4) ¼-20 X 2¼" BOLTS, WASHERS AND NUTS IN PRE-DRILLED HOLES (C)

*CAUTION DO NOT USE WASHERS UNDER NUT

* TIGHTEN ALL NUTS AT THIS TIME. ASSEMBLY IS NOW COMPLETE.

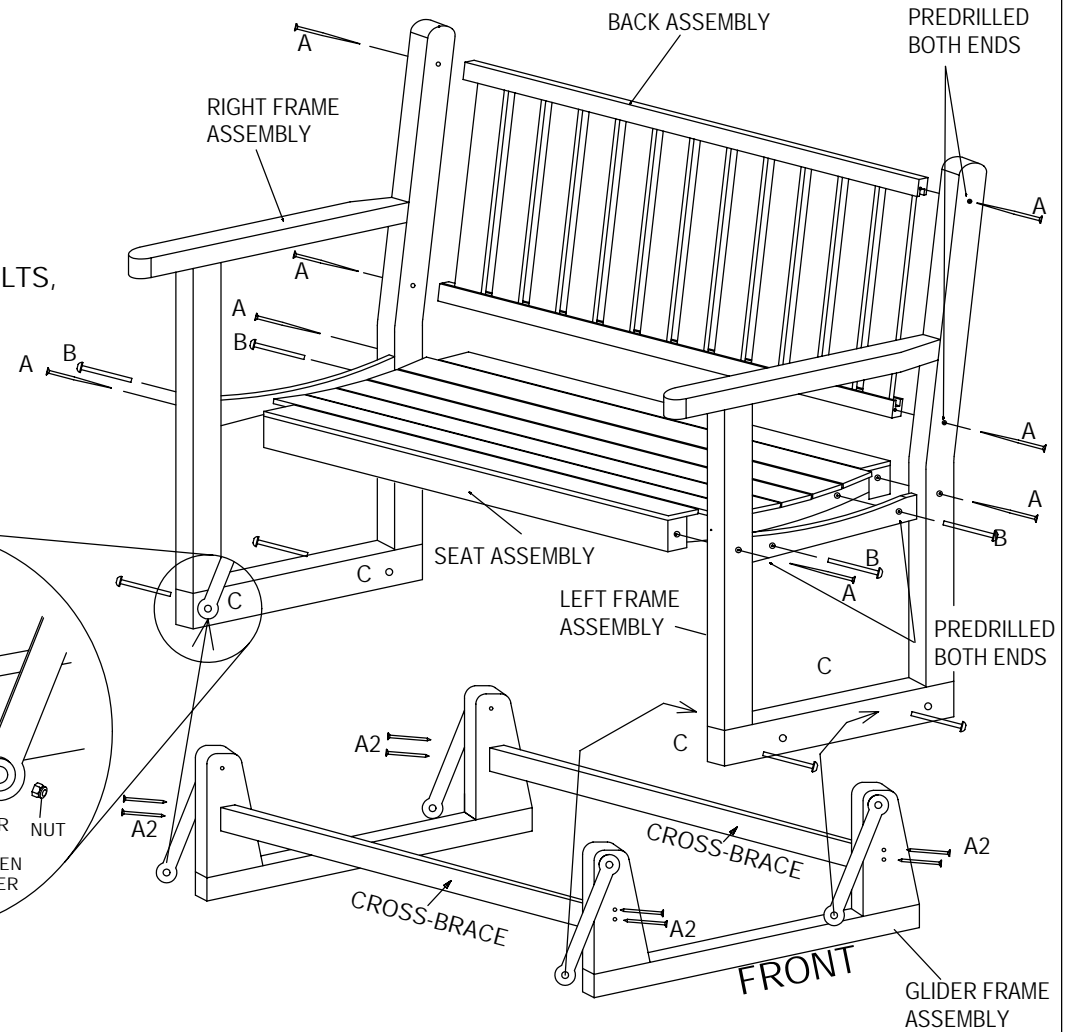
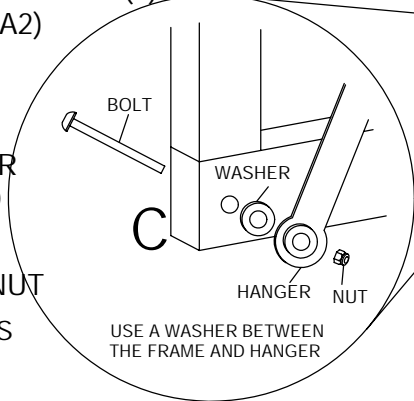

LETTER	QTY.	DESCRIPTION
A	16	#10X3" PAINTED SCREW
B	4	¼ -20 x 2½" TRUSS BOLT
B,C	8	¼" FLAT WASHER
B,C	8	¼-20 LOCK NUT
C	4	¼ -20 x 2¼" TRUSS BOLT

TOOLS NEEDED

PHILLIPS HEAD SCREWDRIVER
A SCREW GUN IS RECOMMENDED
7/16 SOCKET DRIVER