

ASSEMBLY INSTRUCTIONS

SKU# LFW006-1

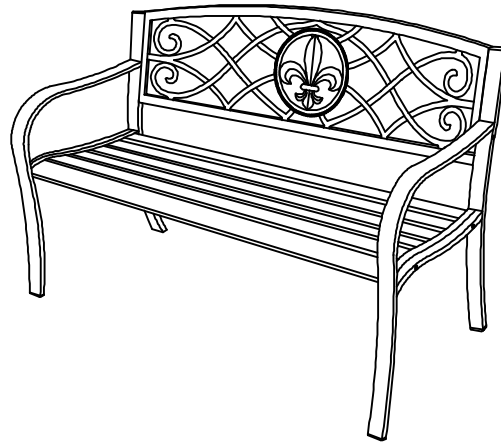







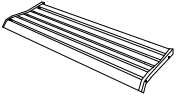
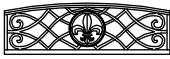
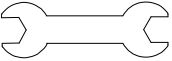

READ & SAVE THESE INSTRUCTIONS:

Please read instructions carefully and identify all parts before assembly.

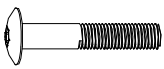
- Assemble your unit in an area free from any object that might scratch the surface of your unit.
- Examine all packing material before discarding, shortages may occur from parts left in the packing material.
- Follow step by step instruction.

Parts List

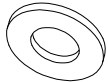
NO.	PARTS	DESCRIPTION	Q'TY	NO.	PARTS	DESCRIPTION	Q'TY
A		RIGHT LEG	1PC	B		LEFT LEG	1PC
C		SEAT	1PC	D		BACK	1PC
E		WRENCH	1PC	F		HEXAGONAL WRENCH	1PC
G		BOLT 70MM	4PCS	H		BOLT 50MM	4PCS
I		HEXAGONAL NUT	8PCS	J		CAPS	8PCS
K		WASHER	8PCS				

ASSEMBLY INSTRUCTIONS

SKU# LFW006-1

PREPARATION

- Remove all parts from packaging. Check the parts quantity mentioned on parts list.
- Spread out all parts on a sofa, level surface to avoid scratching parts.
Do not tighten nuts with wrench until assembly is complete.

Step 1:

Attach back (D) to legs (A & B) using bolts (G), washers (K), and nuts (I) as shown.

Attach Seat (C) to legs (A & B) using bolts (K), washers (K), and nuts (I) as shown.

Repeat on the other side.

Do not tighten bolts (G & H) until seat (C) and back (D) are in place and bench is at 90 degrees with floor.

At last, use wrench (E) to hold the hexagonal nut (I) and the Hexagonal wrench (F) on the bolt to tighten the bolts (G & H) and cover the nuts (I) with caps (J).

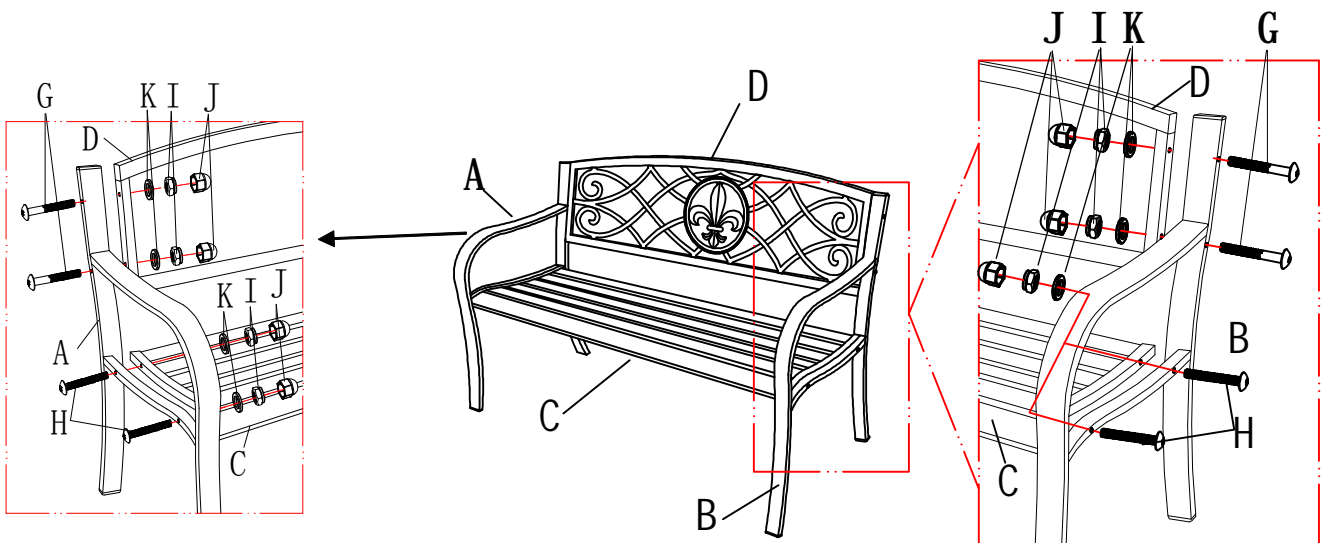

Step 2

Your bench is now completely assembled and ready for use.

